

# Roller Conveyor M1850

# MONK

## Roller sizes 30 & 50mm diameter

Roller widths 200mm to 1000mm.  
 Free running gravity track or motor driven.  
 Section lengths 1m to 4m.  
 Standard rollers 50mm diameter - also 30, 40.  
 Side members 80mm x 40mm M48T extrusion.  
 Fully compatible with our MONEX<sub>40</sub> extrusion.  
 Optional stainless steel side guides.  
 Fixed or variable speed drives.  
 Standard motors 230v or 415v.  
 Protection IP65, continuous rating.  
 Linear speeds 4M/min to 50M/min.  
 Rollers: zinc plated steel, stainless steel or plastic.  
 Cable duct combined in frame members.  
 Style matches our flat belt conveyors.  
 Food quality stainless steel available.  
 Zero line pressure accumulation version.

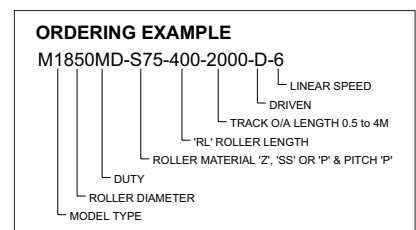
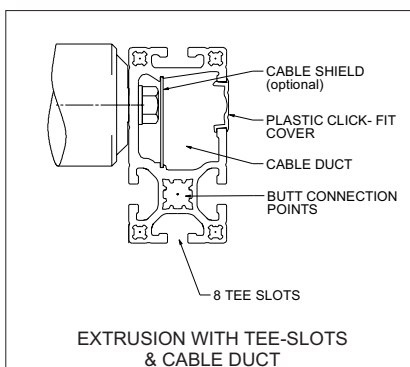
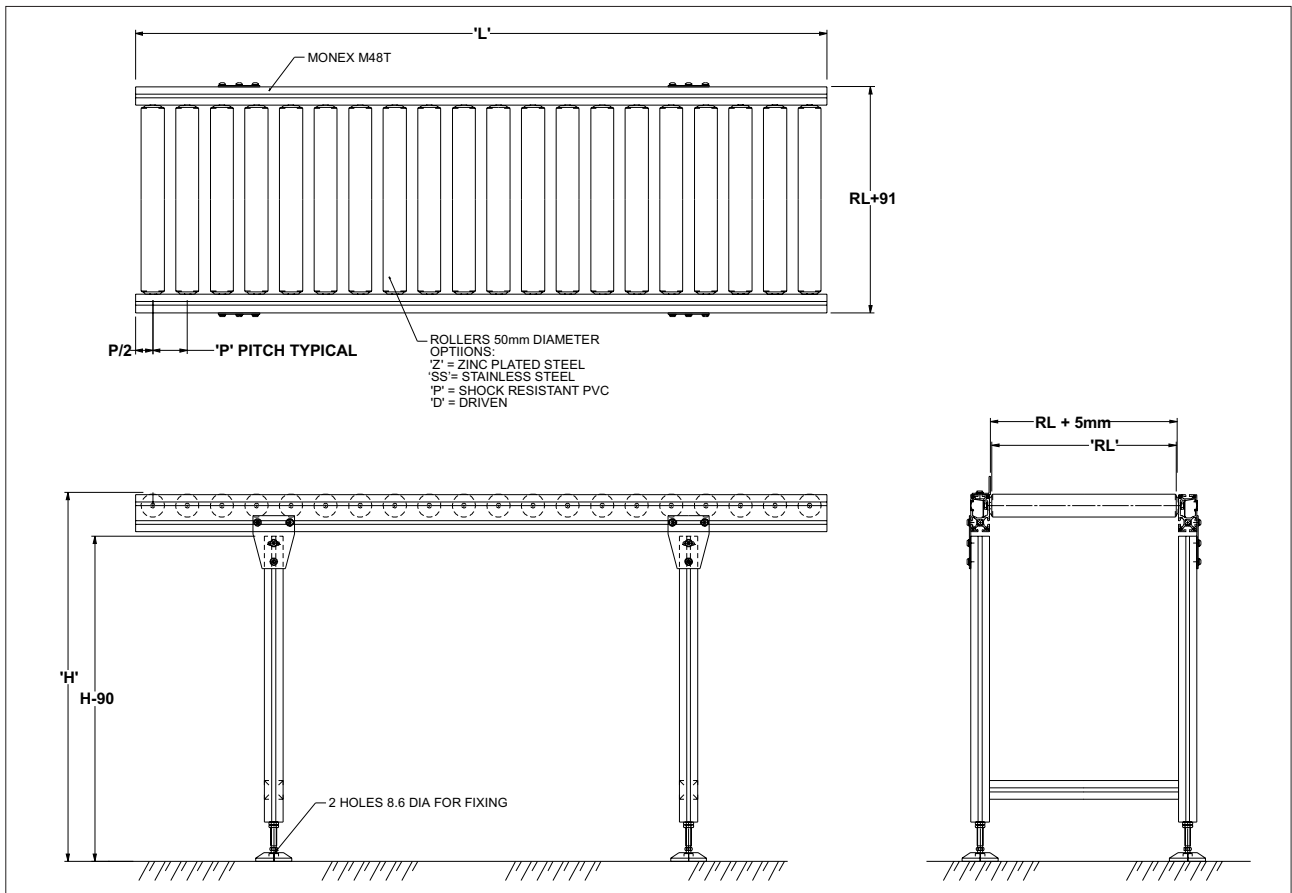

### Monk Conveyors Limited

Woodside House, Woodside Park, Catteshall Lane, Godalming, Surrey GU7 1LG  
 Tel: 01483 791700 Fax: 01483 791701 Email: sales@monk-automation.co.uk

[www.monk-automation.co.uk](http://www.monk-automation.co.uk)