

# Mini Stainless Steel Conveyor M1932-SS **MONK**

## Roller size 32mm diameter

Suitable for meat, poultry and fish.  
 Belt width 80 to 300mm.  
 Length 600mm to 2 meters.  
 Backbone 38mm deep.  
 M8 fixings  
 Bed plate stainless steel.  
 Optional stainless steel / plastic side guides.  
 Motors 230v or 415v/3ph/50hz.  
 Thermal overload protection switch.  
 Continuous rating.  
 B class insulation & terminal box to IP54 or 65  
 Belt speeds from 0.1m.min to 26m/min.  
 Variable speed option.  
 Choice of stand type.  
 Food quality belts - blue or white.

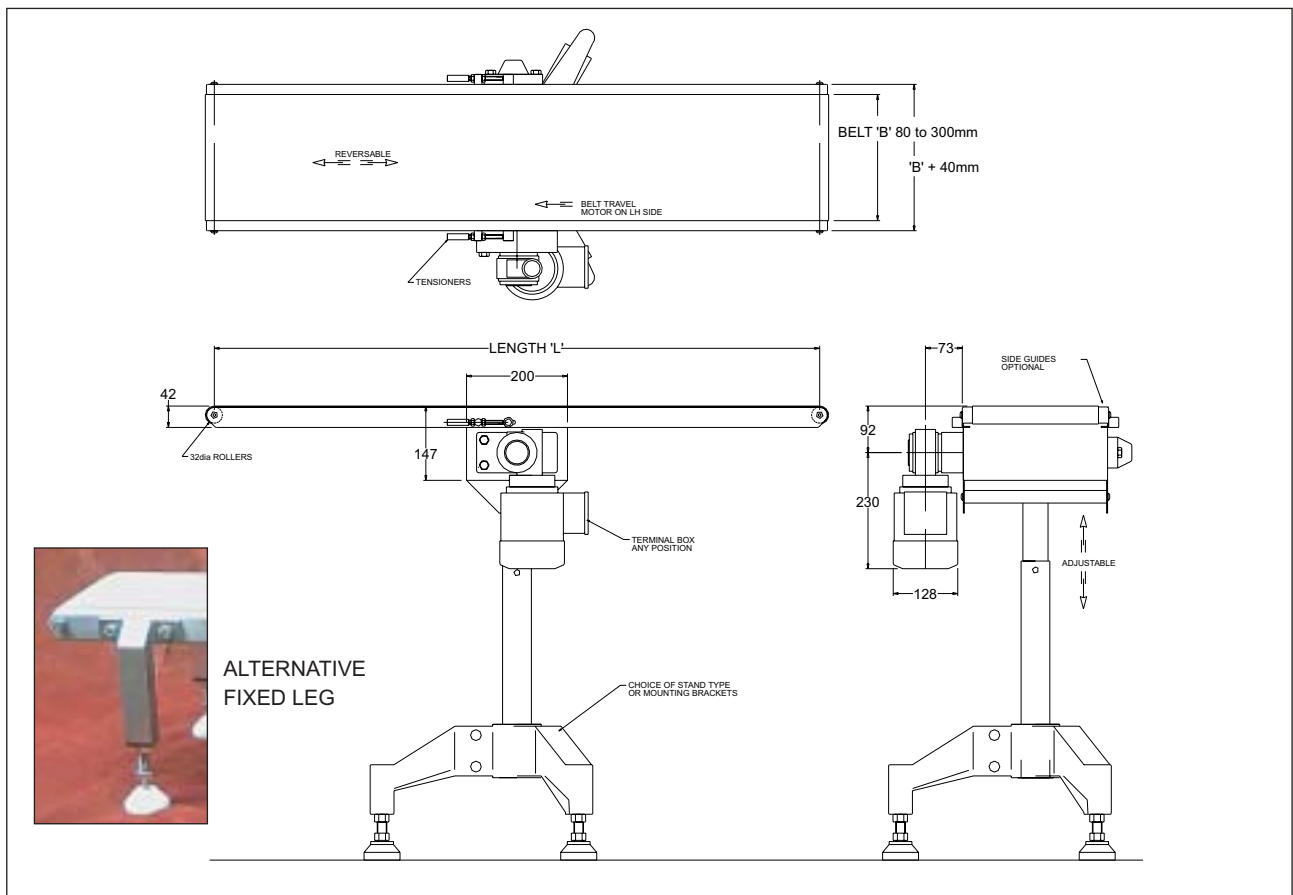

### FIXED SPEED M1932-SS-CDF

BELT SPEED M/min26
41
29
19
14
10
7
5

### VARIABLE SPEED M1932-SS-CDV

BELT SPEED M/min	
MIN	MAX
4	41
3	29
2	19
1.5	14
1	10
0.7	7
0.5	5

### ORDERING EXAMPLE

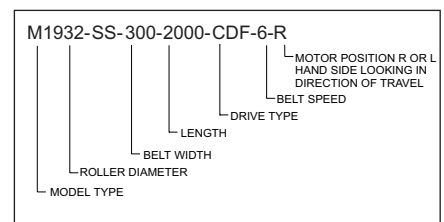

HIGHER & LOWER SPEEDS AVAILABLE ON REQUEST

**Monk Conveyors Limited** Woodside House, Woodside Park, Catteshall Lane, Godalming, Surrey GU7 1LG

Tel: 01483 791700 Fax: 01483 791701 Email: sales@monk-automation.co.uk [www.monk-conveyors.co.uk](http://www.monk-conveyors.co.uk)