

# ***AFD1200***

## **Wet-Sander**

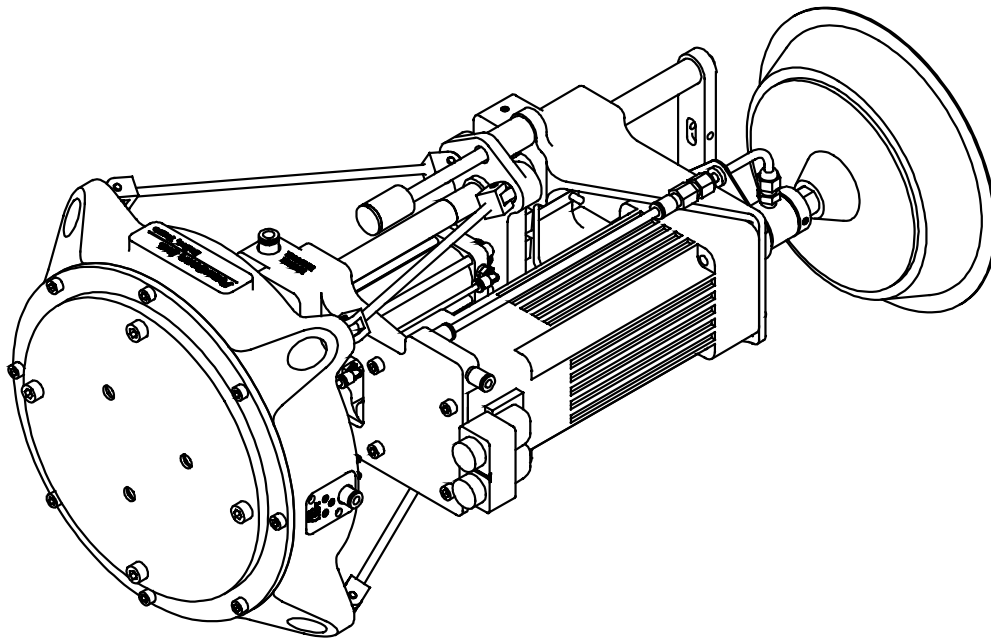

## **Manual**

*PUSHCORP, INC.*

---

**Dallas, Texas**

January, 2000

PAR01330-2

## **CAUTION**

**Active Force Devices contain  
calibrated electronics.**

**HANDLE WITH CARE**

**DO NOT DROP**

## **DO NOT USE LUBRICATED AIR.**

**This device requires a dry, non-lubricated 80 to 90 psi (5.5 – 6.2 bar) air supply filtered to 5  $\mu\text{m}$  and a 0.3 micron oil mist separator.**

**Non-compliance with these requirements will void the manufacturer's warranty.**

**(See Section 3.2)**

## **CAUTION**

**DO NOT spin the Servo Sanding Motor without supplying water**

## **NOTE**

**All fasteners, mounting holes and pipe threads on this tool are METRIC.**

## ***Table of Contents***

<b>1.0 LIMITED WARRANTY .....</b>	<b>1</b>
<b>2.0 GENERAL OVERVIEW .....</b>	<b>3</b>
<b>3.0 INSTALLATION .....</b>	<b>4</b>
3.1 Mounting the <i>AFD1200</i> .....	4
3.2 Air Supply .....	5
3.3 Water Connections .....	7
3.4 Electrical Connections.....	8
4.0 Wetsanding Pad Removal and Replacement .....	8
<b>4.0 TECHNICAL SPECIFICATIONS.....</b>	<b>9</b>

## **1.0 Limited Warranty**

### **Duration:**

One year from date of delivery to the original purchaser.

### **Who gives this warranty (warrantor):**

*PushCorp, Inc.*

Telephone: (972) 840-0208

Corporate Address:

P. O. Box 181915

Dallas, Texas 75218

Shipping Address:

2345 Merritt Drive

Garland, Texas 75041

### **Who receives this warranty (purchaser):**

The original purchaser (other than for purposes of resale) of the *PushCorp, Inc.* product

### **What products are covered by this warranty:**

Any *PushCorp, Inc.* industrial equipment or accessory supplied or manufactured by the Warrantor.

### **What is covered under this warranty:**

Defects in material and/or workmanship, which occur within the duration of the warranty period.

### **What is NOT covered in this warranty:**

- A. IMPLIED WARRANTIES, INCLUDING THOSE OF MERCHANTABILITY AND FITNESS FOR A PARTICULAR PURPOSE ARE LIMITED TO ONE YEAR FROM THE DATE OF ORIGINAL PURCHASE. Some states do not allow limitations on how long an implied warranty lasts, so the above limitations may not apply to you.
- B. ANY INCIDENTAL, INDIRECT, OR CONSEQUENTIAL LOSS, DAMAGE or EXPENSE THAT MAY RESULT FROM ANY DEFECT, FAILURE, MALFUNCTION OF THE *PUSHCORP, INC.* PRODUCT. Some states do not allow the exclusion or limitation of incidental or consequential damages so the above limitation or exclusion may not apply to you.
- C. Any failure that results from an accident, purchaser's abuse, neglect, unauthorized repair or failure to operate the products in accordance with the instructions provided in the owner's manual(s) supplied with the product.

### **Responsibilities of the Warrantor under this warranty:**

Repair or replace, at Warrantor's option, products or components which have failed within the duration of the warranty period.

**Responsibilities of the purchaser under this warranty:**

- A. Deliver or ship the *PushCorp, Inc.* product or component to PushCorp, Inc. Service Center, Dallas, TX. Freight and insurance costs, if any, must be borne by the purchaser.
- B. Use reasonable care in the operation and maintenance of the product as described in the owner's manual(s).

**When warrantor will perform repair or replacement under this warranty:**

Repair or replacement will be scheduled and serviced according to the normal workflow at the service center, and depending on the availability of replacement parts. Purchasers requiring quicker repair may receive such with payment of a *PushCorp, Inc.* predetermined expediting fee.

This Limited Warranty gives you specific legal rights and you may also have other rights, which vary, from state to state.

## 2.0 General Overview

The *PushCorp, Inc. AFD1200 Wet Sander* and *FCU1000 Active Compliance Controller* (US Patent No. 5,448,146) provide a superior robotic surface finishing system. The *AFD1200* is an end of arm robotic device specifically designed to perform wet sanding operations. The Wet Sander system enables a robot to manipulate an abrasive media over any contoured surface with an extremely precise, consistent, compliant force. This unique capability gives the robot the ability to excel in a traditionally expensive and inconsistent manual process. The Wet Sander coupled with a robot delivers results that are virtually impossible to duplicate with a manual operation.

To achieve this superior performance, the *AFD1200 Wet Sander* utilizes *PushCorp* patented active force control technology. This technology is realized through the use of a pneumatic actuator to provide the sanding force and a load-cell force sensor to provide closed-loop feedback to the control unit. The pneumatic actuator provides the force and necessary compliance by moving the sanding motor along linear rods. These linear rods allow a 3.0 inch (80mm) stroke enabling the sanding pads to remain in contact with the part, and apply the correct force, regardless of any robot/part misalignment. Also, the *AFD1200* contains an accelerometer that monitors the spacial orientation and allows the unit to automatically compensate for gravitational and inertial effects to maintain the desired sanding force. Finally, a linear potentiometer, located within the pneumatic actuator, senses the position of the Wet Sander motor along the linear rods.

The *AFD1200* has several unique features to endure the harsh conditions found in a typical wet sanding environment. A primary feature is that *AFD1200* is water-resistant, allowing the tool to be washed down. The tool's main linear bearings are hydrostatic and float on Stainless Steel linear rods using water pressure. This method has been chosen to resist rust and corrosion while maintaining the low friction required for precise force control. All of the electronics are sealed in the base housing to prevent any water contamination.

The *AFD1200* is equipped with a variable speed servo sanding motor. The motor is controllable over a -6200 to +6200 rpm speed range. The servo sanding motor is also equipped with an integral water feed-through to supply the abrasive pad with flooding capability.

To control the *AFD1200 Wet Sander* the *FCU1000 Active Compliance Controller* must be used. The unit contains a high-speed microprocessor executing proprietary control algorithms. The microprocessor controller provides several advanced features including automatic motor/tool weighing, automatic motor weight/gravity compensation, and automatic compensation of acceleration induced forces. To facilitate system integration, a remote host computer or PLC controller can be interfaced through high level communications including RS-232 serial, 24 VDC parallel, or analog interfaces.

## 3.0 Installation

### 3.1 Mounting the AFD1200

The AFD1200 Wet Sander attaches to the robot's mounting flange. The Wet Sander is supplied with a removable Mounting Plate. PushCorp, Inc. can provide the Mounting Plate blank, or with a customer specified bolt-hole pattern.

A minimum of three flat-head screws (user supplied) is required to securely attach the Mounting Plate to the robot's mounting flange. These flat-head screws must be installed per the robot manufacturer's instructions.

To mount an AFD1200 first remove the (4) four M8 fasteners that secure the Mounting Plate to the Base. The Mounting Plate is attached to the robot, with the user supplied flat-head fasteners. Then align the AFD1200 Base with the Mounting Plate, and re-install the (4) four M8 fasteners. Torque the M8 fasteners to the value listed in Section 6.0.

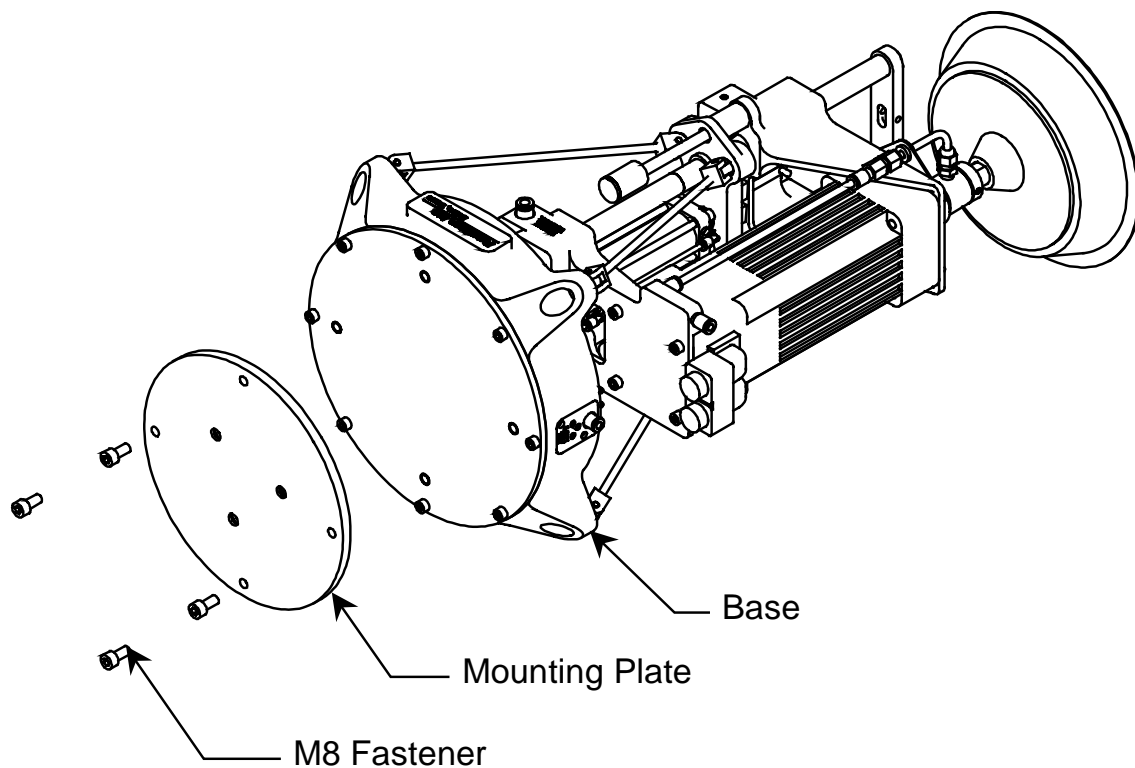

Figure 1. AFD1200 Mounting Scheme

### 3.2 Pneumatic Connection

The AFD1200 Wet Sander requires a dry, non-lubricated, filtered, 80 psi (5.5 bar) to 90 psi (6.2 bar) air supply. The device requires a maximum flow rate of 2.0 cfm (56.6 l/m). Failure to provide supply air to these specifications can degrade performance and will void any warranty repairs concerning pneumatic components. A *minimum* 80 psi (5.5 bar) air pressure must be maintained for the device to operate within published specifications. Operating at lower air pressure can cause inferior force control performance and possibly instability. Operating the AFD1200 at pressures over 90 psi (6.9 bar) will activate a pressure relief valve inside the Base. This valve prevents damage to the load cell due to operating the unit with excessive pressure. This relief valve is strictly a protective mechanism and should not be used as a pressure regulator device.

The Air Supply System should be configured as shown in Figure 2.

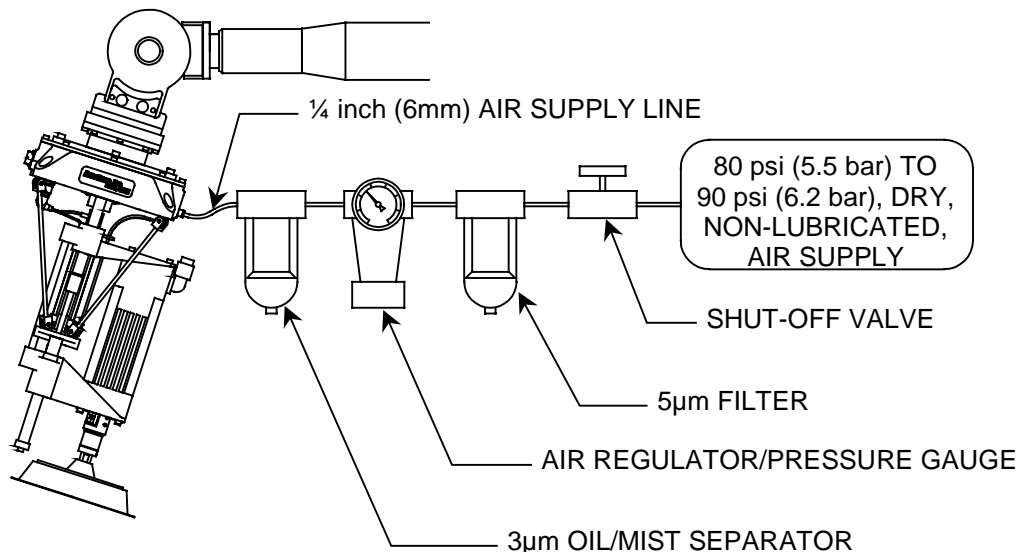

Figure 2. Pneumatic Configuration

If water condensation is a problem in your air supply system, an air dryer device is highly recommended. The ideal solution is an industrial chiller dryer capable of reducing the dewpoint to less than 32° F (0°C). Moisture inside the force device will cause premature failure that will not be covered under warranty.

The AFD1200 Air Supply Port is located on the Wet Sander Base. The port is labeled "AIR (LUFT)". Improper connection to the port will result in failure of the pneumatic and electronic components in the Wet Sander. (See Figure 3) A 6mm tube push-lock fitting is supplied, but if another type of fitting is desired, unscrew the existing fitting and replace it with a suitable fitting having a Rc 1/8 (metric) thread. Be sure to use a thread seal product and do not over tighten the fitting.

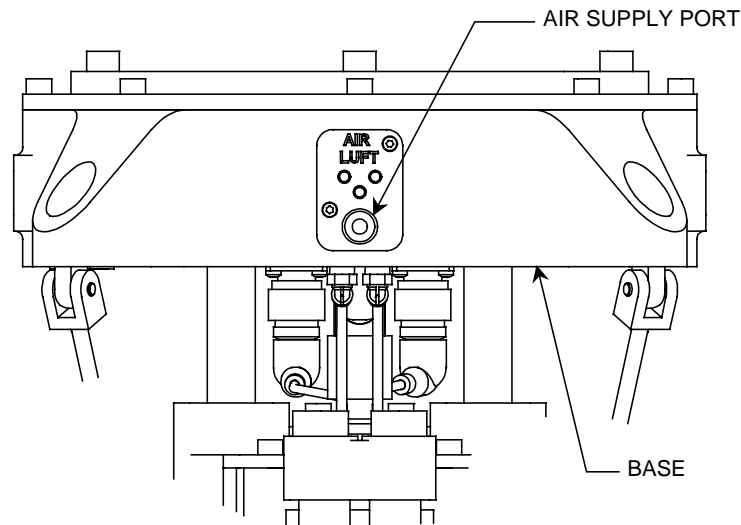

Figure 3. AFD1200 Air Supply Port.

The single Air Supply Line to the device should be  $\frac{1}{4}$  inch (6mm) diameter **flexible polyurethane** tubing. The tubing should be routed to the AFD1200 such that there are no kinks and that there is plenty of slack to allow for any desired manipulator motion. Before attaching the Air Supply Line to the unit, open the Shut-Off Valve to blow out any contaminants which may be in the tubing. Attach the tubing to the Wet Sander Air Supply fitting. Charge the system with compressed air and verify that there are no air leaks and that there is a minimum of 80 psi (5.5 bar) at the Air Supply Port. If a minimum air pressure of 80 psi (5.5 bar) cannot be achieved, then an auxiliary air compressor or booster pump must be installed.

To remove the Air Supply Line, first release all air pressure in the system. Then, if using the *PushCorp* supplied push-lock fitting, push inward on the fitting's ring, then pull the tubing out. Cover or plug the push-lock fitting any time the Air Supply Line is not connected. This will keep any contaminants from entering the unit.

**NOTE: PushCorp highly recommends the use of flexible polyurethane tubing as opposed to nylon tubing. This is because nylon tubing tends to crimp shut when it is bent. This severely limits airflow and may cause erratic operation. Polyurethane tubing is designed to withstand continuous bending cycles and resist crimping.**

### 3.3 Water Connections

The Wet Sander has been designed to operate with standard tap or deionized water. The water supply to the Wet Sander must be clean and free of contamination to ensure proper operation. A water filter is required.

Figure 4 shows the (2) water connections on the AFD1200. The first water connection on the Wet Sander Frame is a 8mm Push-lock Fitting, labeled "WATER (WASSER)". The Hydrostatic Bearing Water Input supplies the hydrostatic bearings. The hydrostatic bearings require pressurized water to provide the force to separate the bearing from the round linear shaft. The greater the water pressure, the greater the bearing load capacity. The AFD1200 requires a minimum 60 psi (4.2 bar) to a maximum 100 psi (6.8 bar) water pressure. Without proper water pressure, the bearing will come into contact with the linear shaft and cause excessive friction and force errors. The second connection is an 8mm push-lock fitting, supplying water to the Servo Motor Water Feedthru.

**CAUTION: Operating the AFD1200 servomotor without supplying water to the water feed bearings could result in bearing failure.**

The Wet Sander water connections are supplied with 8mm tube push-lock fittings, but if another type of fitting is desired, unscrew the existing fitting and replace it with a suitable fitting having a Rc 1/8 (metric) thread. Be sure to use a thread seal product and do not over tighten the fitting.

The Water Supply Lines to the Wet Sander should be *flexible polyurethane* tubing. The tubing should be routed to the AFD1200 such that there are no kinks and that there is plenty of slack to allow for any desired manipulator motion.

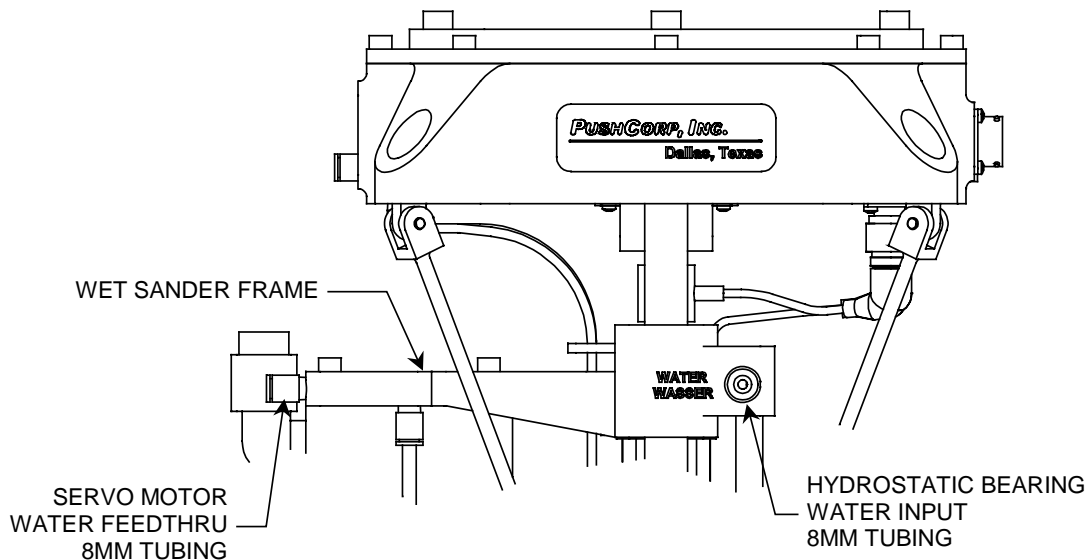

Figure 4. AFD1200 Water Connections

### 3.4 Electrical Connections

Figure 5 shows the electrical cable connections for the *AFD1200* Wet Sander. For additional instructions concerning the *FCU1000* Controller Cable, please refer to the *FCU1000 Manual*. Please refer to the Kollmorgen™ Servo Motor documentation for detailed information regarding motor connections and setup.

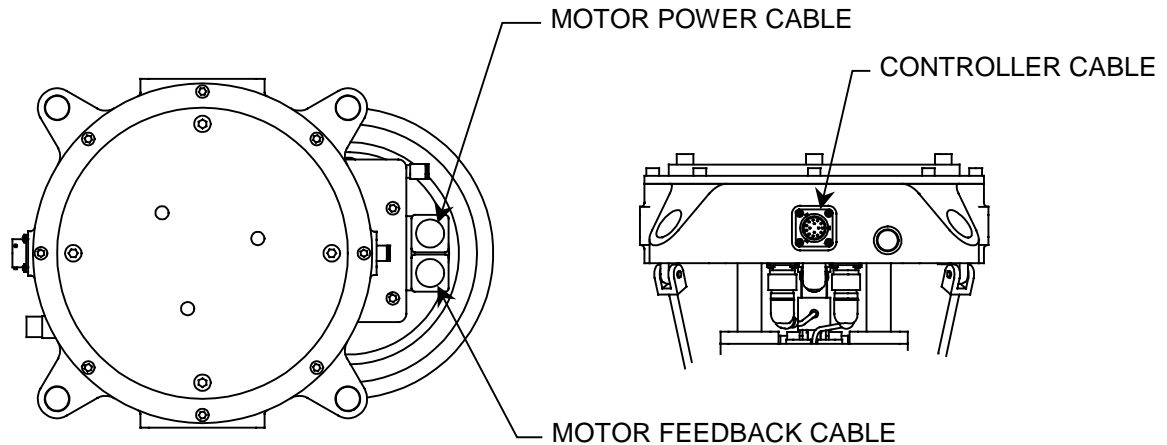

Figure 5. Electrical Cable Connections

### 4.0 Wetsanding Pad Removal and Replacement

The *AFD1200* Wet Sander accepts standard 5/8–11 right-hand threaded wet-sanding pads.

To remove a worn Wet Sanding Pad from the *AFD1200* first ensure all power to the Wet-Sander and Robot is disconnected. Then use an open-end wrench to hold the 18mm Wrench Flats on the Wet Sander Shaft. The Wet Sanding Pad may then be unscrewed. A new Wet Sanding Pad can then be threaded onto the Wet Sander shaft. See Figure 6.

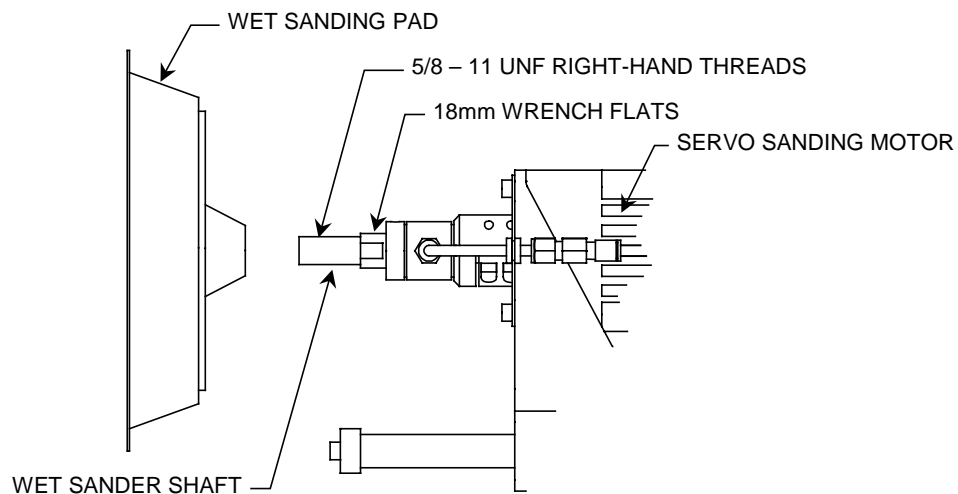

Figure 6. Wet Sanding Pad Removal and Replacement

## 5.0 Technical Specifications

Maximum Applied Force:	100 lb. (444 N)
Force Resolution:	+/-0.5 lb. (+/-2.2 N)
Compliant Stroke:	3 in. (76 mm)
Servo Motor:	3.8 hp (2.8 kW)
	6200 rpm
Weight:	48 lb. (22.8 kg)
Temperature:	50° to 122° F (10° to 50° C)
Humidity:	5% to 95%, Non-Condensing
Supply air:	Non-lubricated, Dry, 5µm Filtered, 80-90 psi (5.5-6.2 bar)
	2 SCFM (28 l/min)
Hydrostatic Bearing:	60 psi (4.1 bar) Min., 100 psi (6.9 bar) Max.
Water Pressure	

*Specifications subject to change without notice.*

Fastener Tightening Torque Specs					
Fastener Size	Torque			Minimum Depth	
	in.-lbs.	ft.-lbs.	N·m	in.	mm
M4 x .7	50	4.2	5.6	0.17	4.3
M5 x .8	85	7.1	9.6	0.21	5.3
M6 x 1	140	11.7	15.8	0.25	6.3
M8 x 1.25	348	29.0	39.3	0.33	8.4
M10 x 1.5	600	50.0	67.8	0.41	10.5